

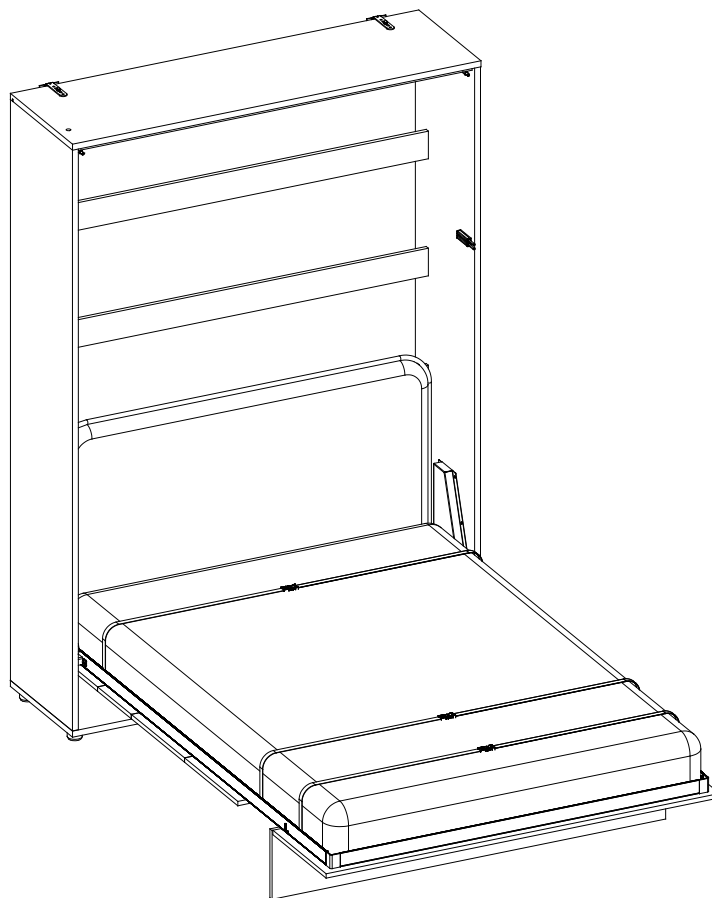

- PL -Montaż powinnien być przeprowadzony zgodnie z instrukcją montażu producenta, w przeciwnym razie może pojawić się niebezpieczeństwo użytkowania.
 DE- Die Installation sollte gemäß den Installationsanweisungen des Herstellers erfolgen, da sonst die Gefahr einer Verwendung besteht.
 EN- Installation should be carried out in accordance with the manufacturer's installation instructions, otherwise there may be danger of use.
 CZ- Instalace by měla být provedena v souladu s instalačními pokyny výrobce, jinak může dojít k nebezpečí použití.
 SK- Inštalácia by sa mala vykonávať v súlade s inštaláčnymi pokynmi výrobcu, inak môže existovať nebezpečenstvo použitia.
 RU- Установка должна выполняться в соответствии с инструкциями производителя по установке, в противном случае может возникнуть опасность использования.
 SRB- Instalaciju treba izvesti u skladu sa uputstvima za ugradnju proizvođača, jer u suprotnom može doći do opasnosti od uporabe.
 HR- Instalaciju treba izvoditi u skladu s uputama za ugradnju proizvođača, jer u suprotnom može doći do opasnosti od uporabe.
 HU- A telepítést a gyártó telepítési útmutatója szerint kell elvégezni, különben a használat veszélye áll fenn.

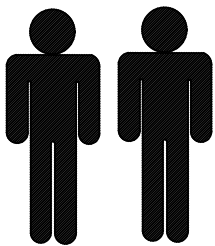

- PL Film instruktażowy.
 DE Lehrvideo.
 EN Instructional video.
 CZ Instruktažní video.
 SK Inštruktážne video.
 RU Учебное видео.
 SR Видео са упутствима.
 HR Video s uputama.
 HU Oktató videó.



60 min



Company: DIG-NET sp. z o. o. sp. k.
 Mroczeń 65a, 63-611 Mroczeń
 e-mail: info@dignet.eu
 NIP:6191953919

Potrzebne narzędzia/ Benötigtes Werkzeug/ Required tools/ Potřebné nástroje/
 Potrebne nástroje/ Необходимые инструменты/ Potreban alat/ Szereléshez szükséges szerszámok

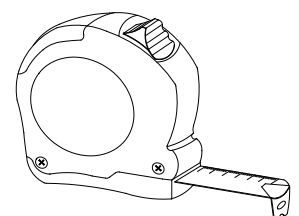
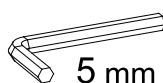
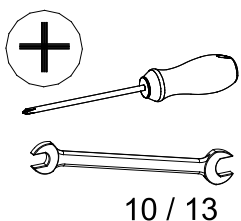

ZAG140	1360,0	730,0	100,0	1	1/1
--------	--------	-------	-------	---	-----

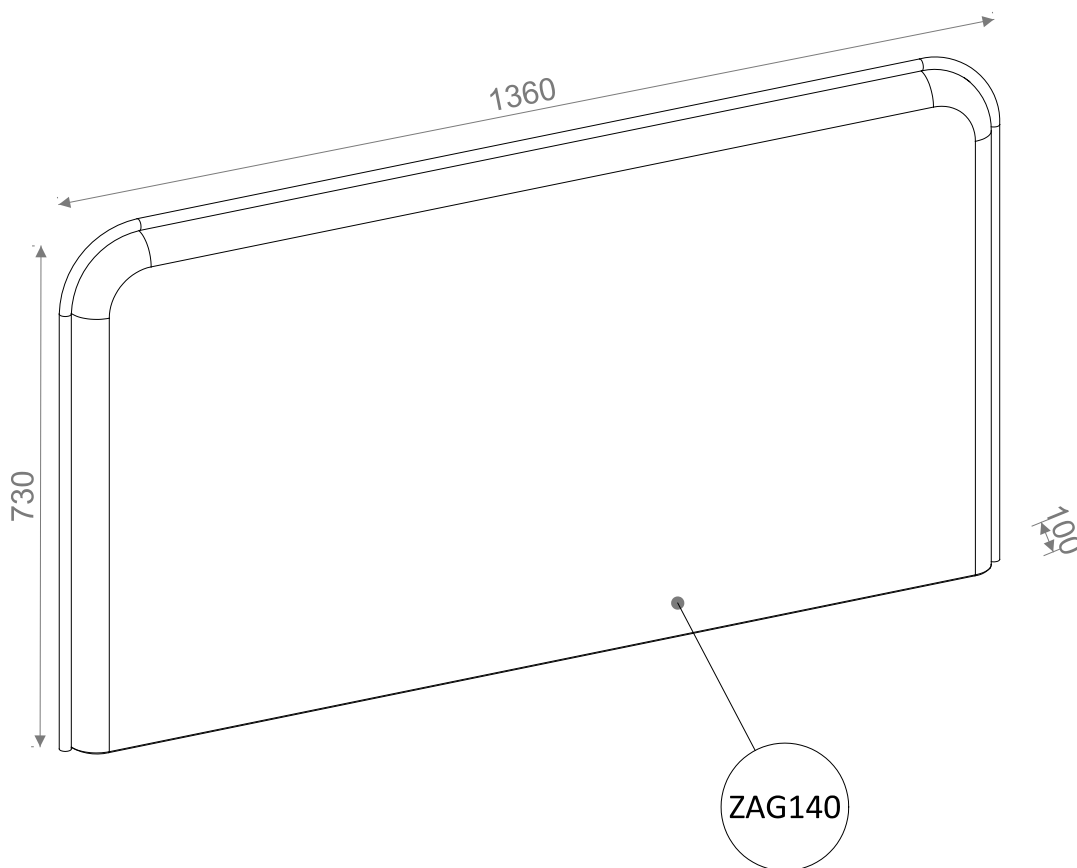
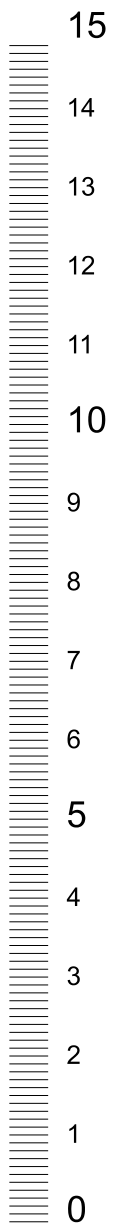
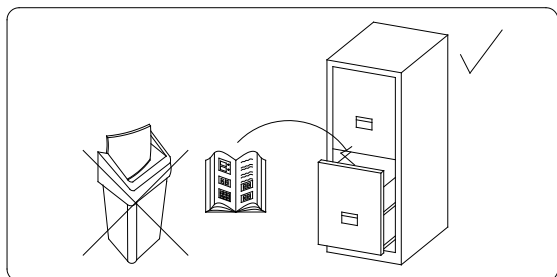

KL4 4 mm 	S56 6x60 3x 	M6 3x 	P6 6x18 3x 	
SPI2 M8.0x20 3x 	UZBC 3x 	W14 4,5x20 6x 	W5 3,5x25 2x 	PZBCC 1x

Proszę sprawdzić kompletność okuć przed montażem
 Bitte überprüfen Sie die Vollständigkeit der Fittings vor der Montage
 Please check the completeness of the fittings before assembly
 Пожалуйста, проверьте комплектность фурнитуры перед установкой

Prosím zkontrolujte úplnost konektorů před instalací
 Prosím skontrolujte úplnosť konektorov pred inštaláciou
 Prije montaže provjerite cjelovitost okova
 Pre postavljanja proverite kompletnost okova
 Kérjük, ellenőrizze a szerelvények teljességét a szerelés előtt

1

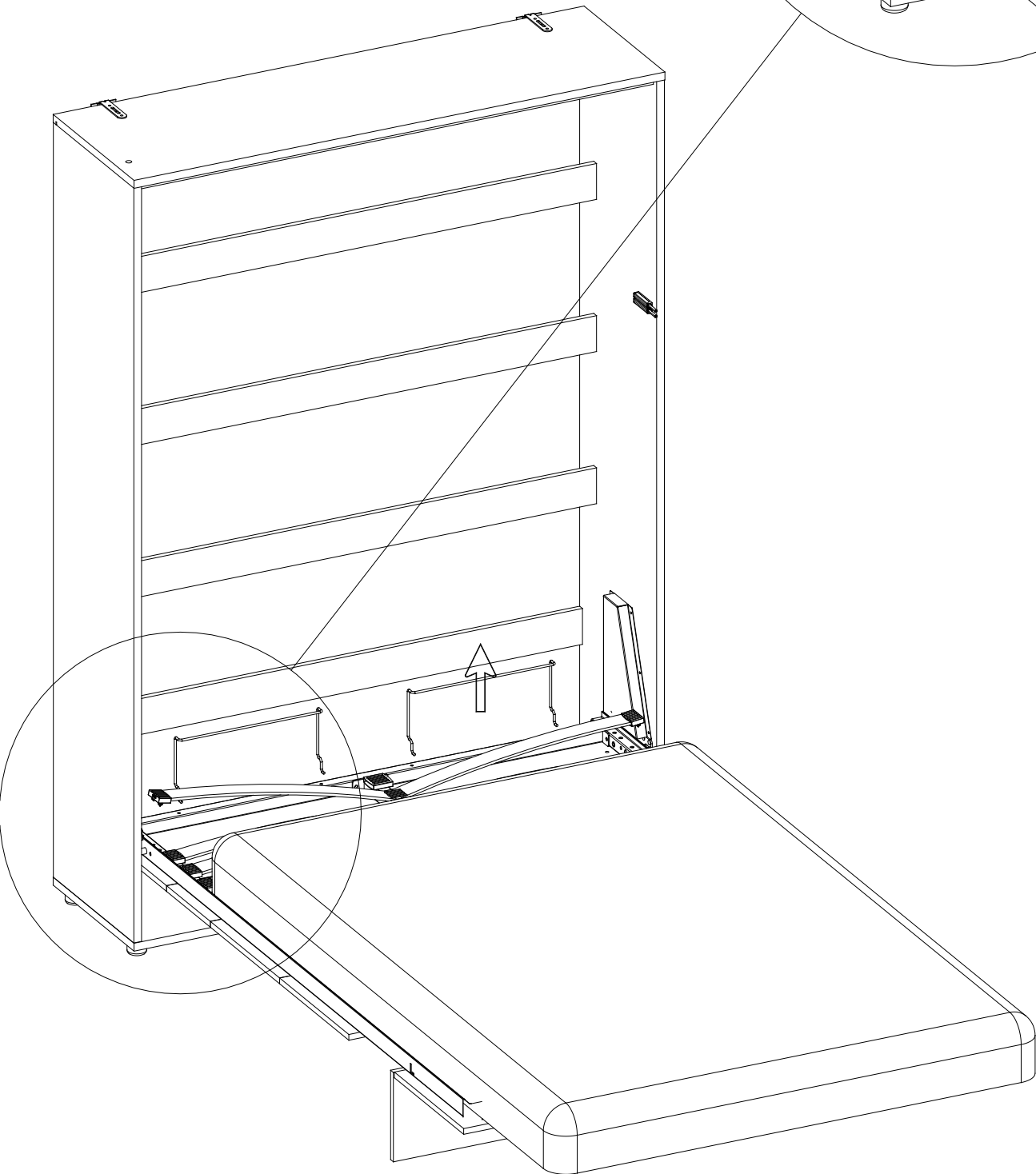
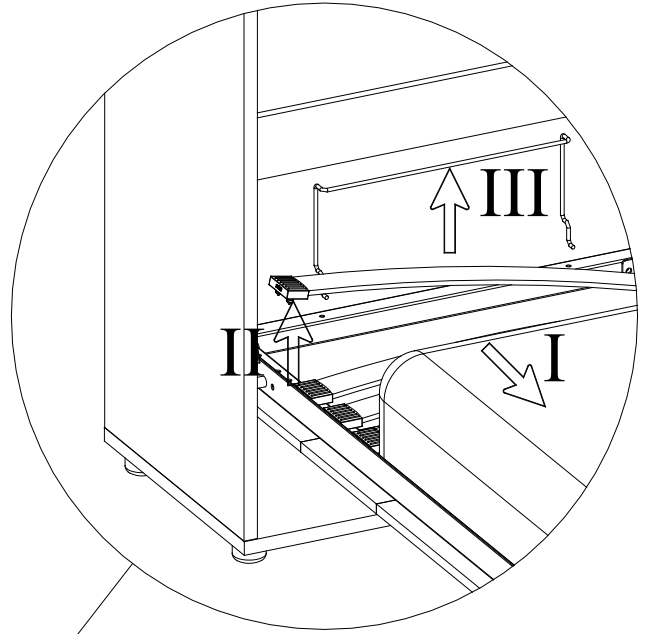

VERSION A 2-3



VERSION B 4-5

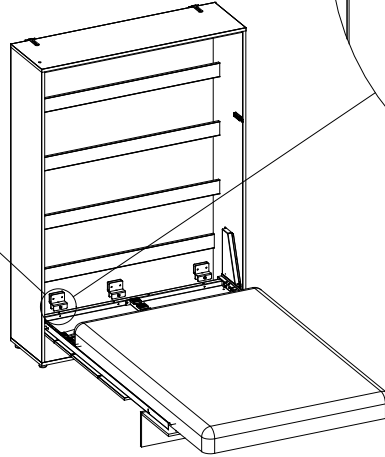
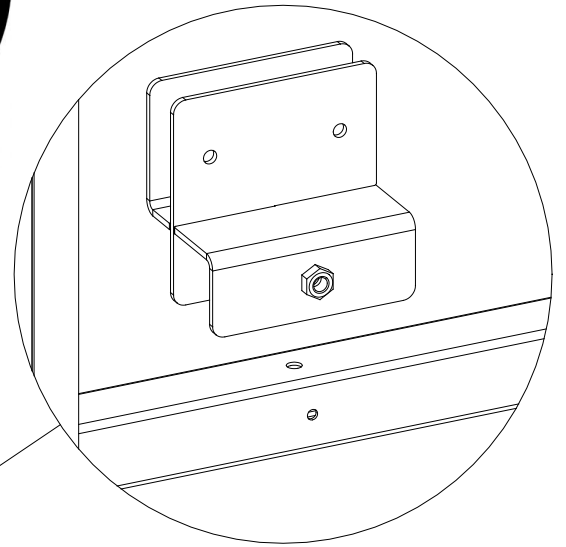
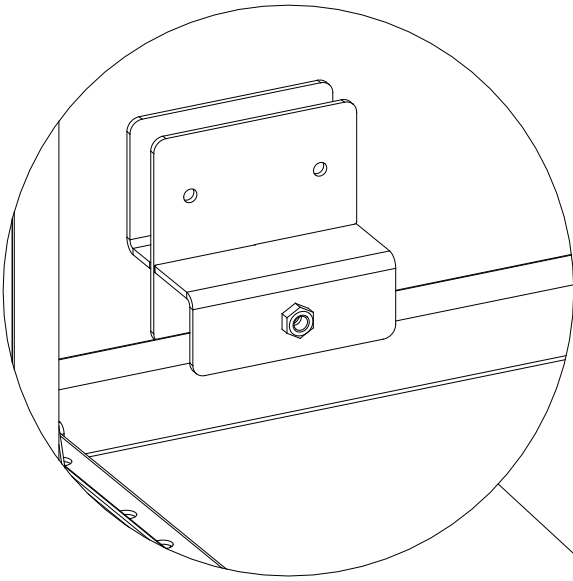

2

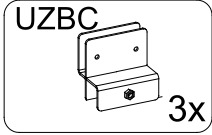

VERSION A

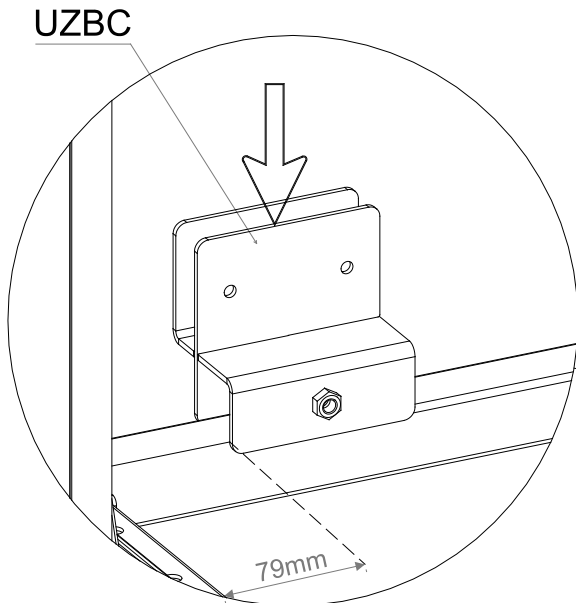
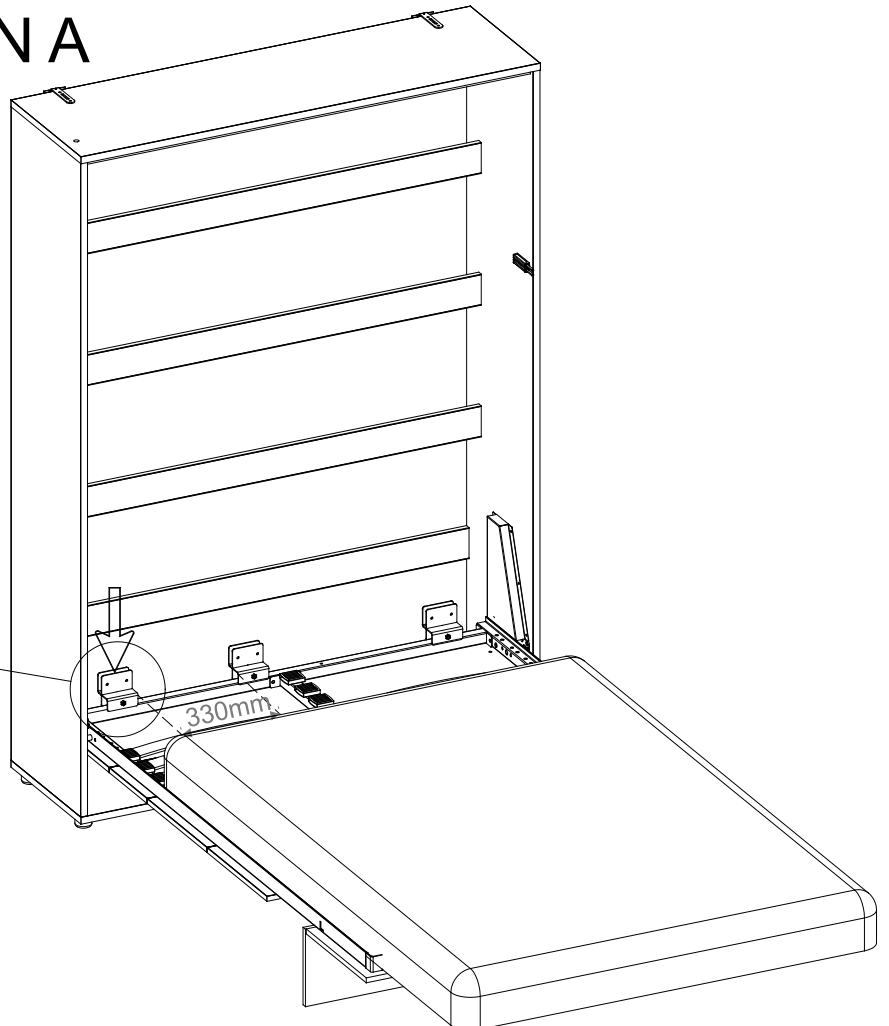

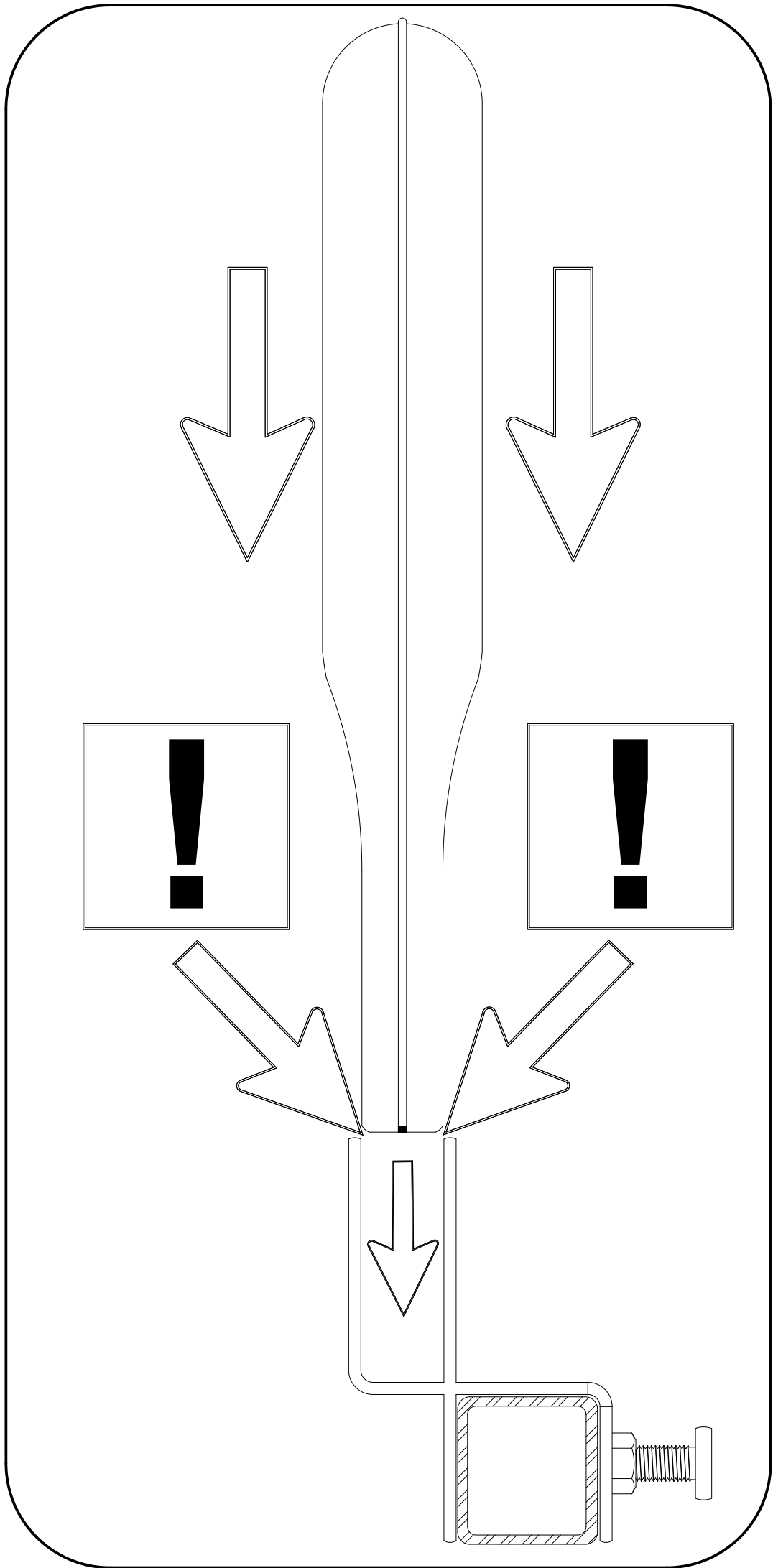

3

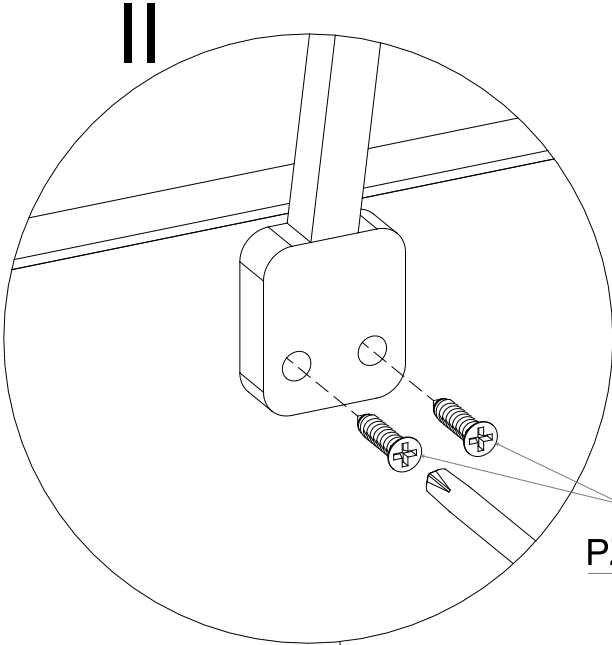
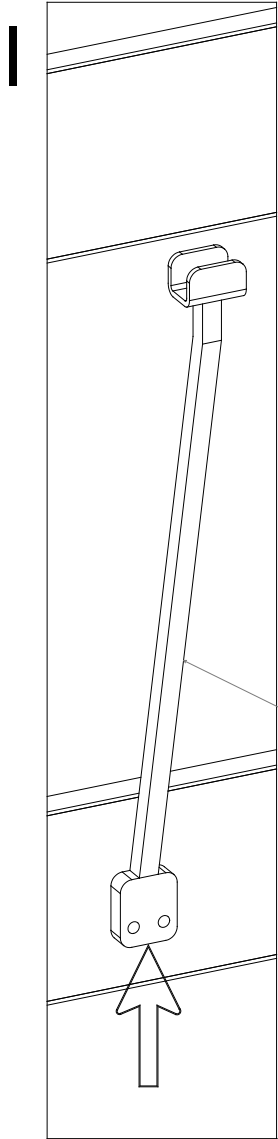
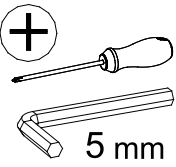
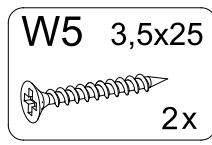
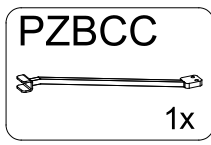
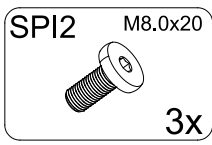

W5
PZBCC

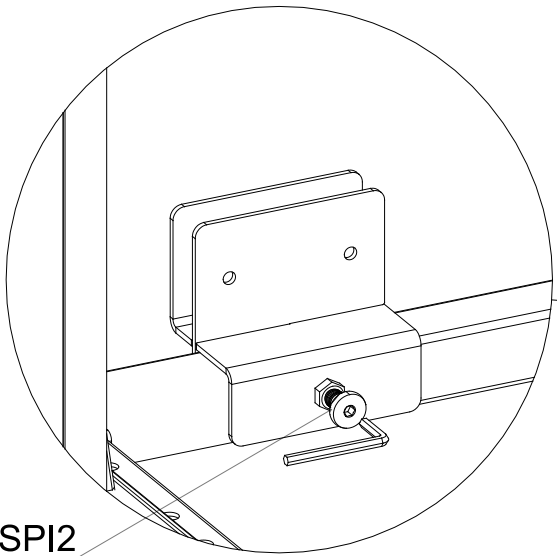
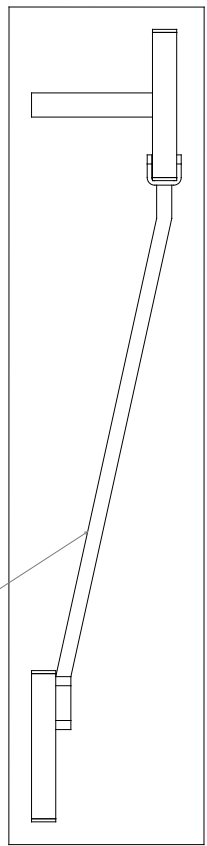

SPI2

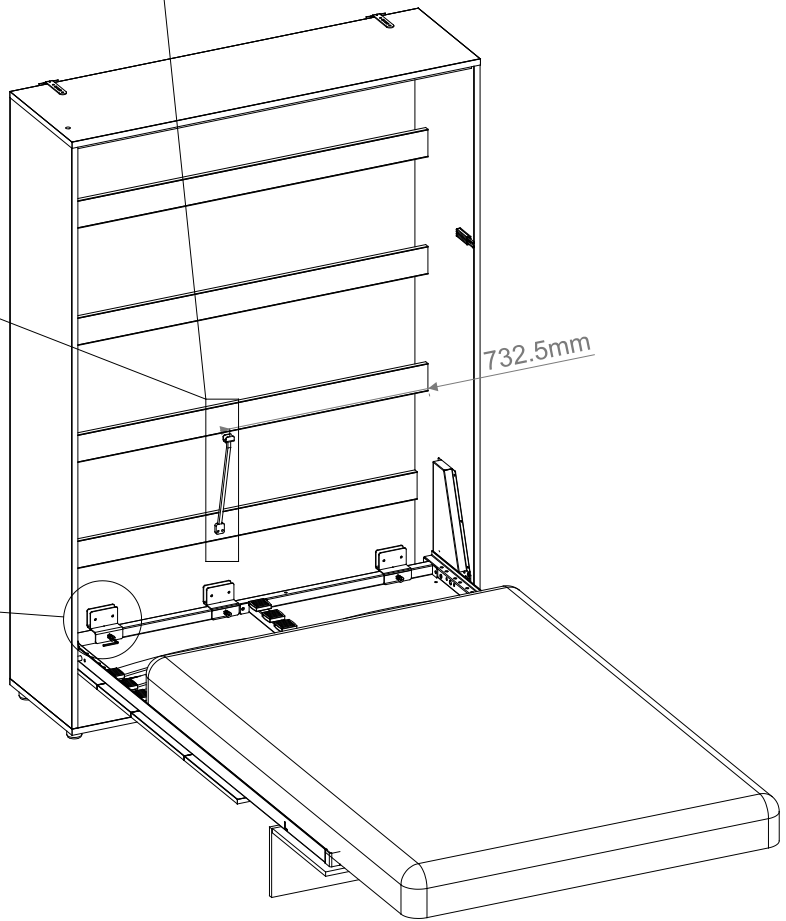

732.5mm

4

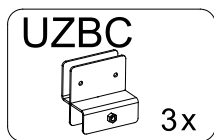

VERSION B

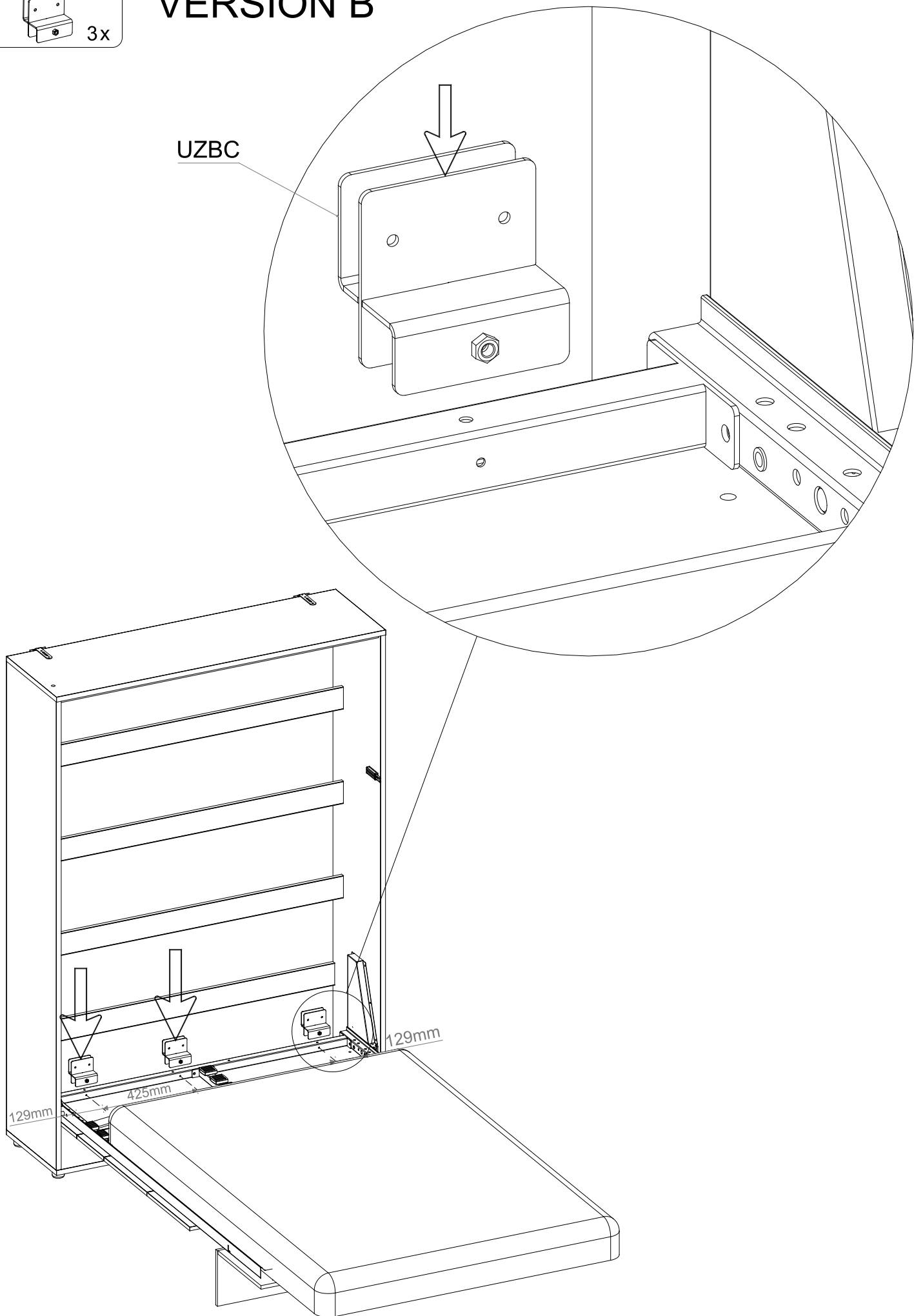

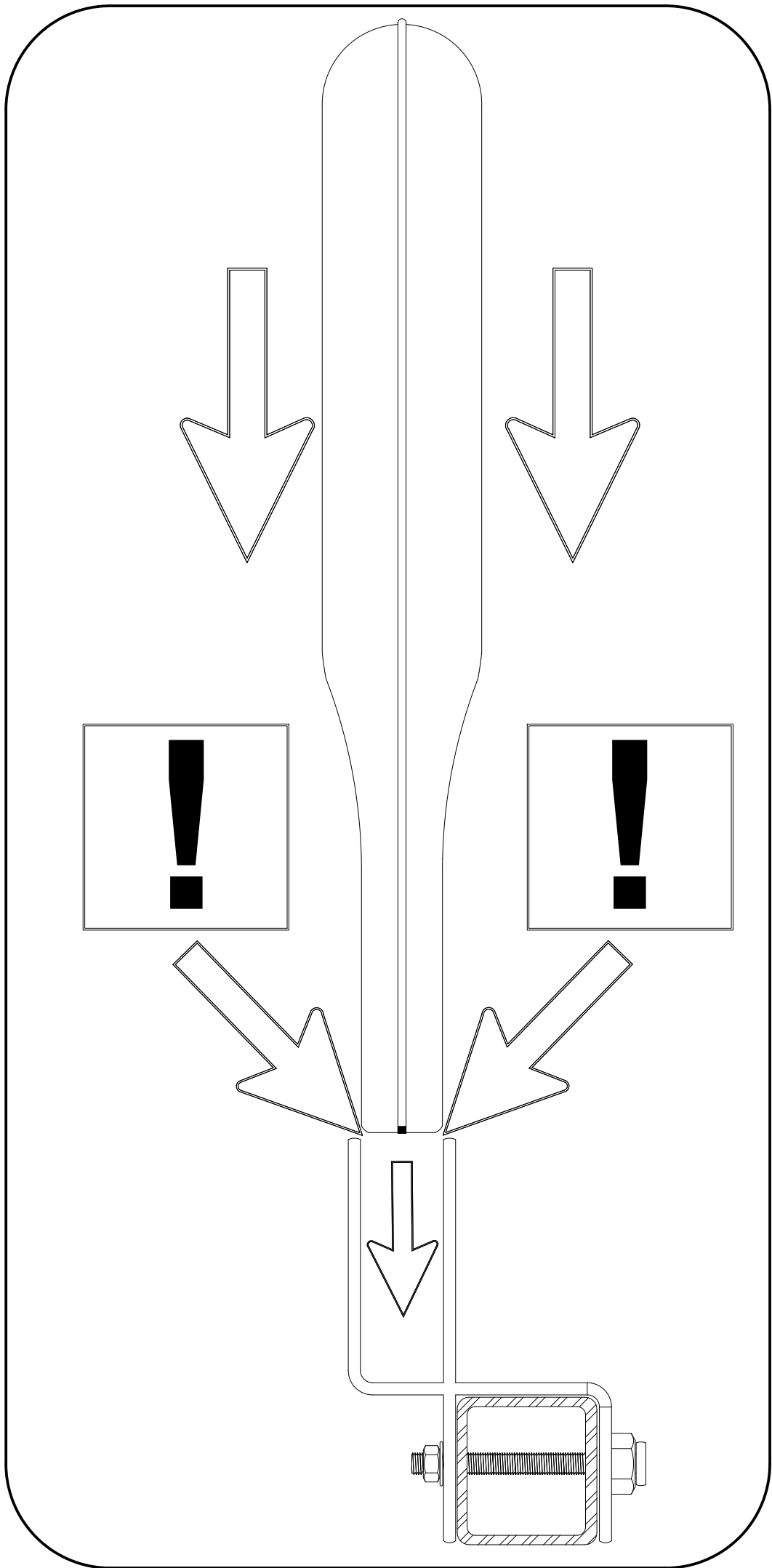

5

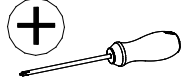
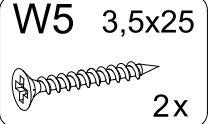
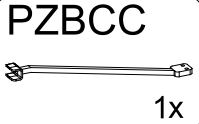
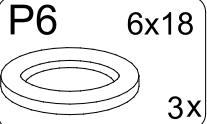
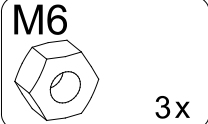
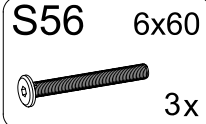
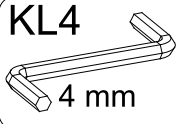

10 / 13

II

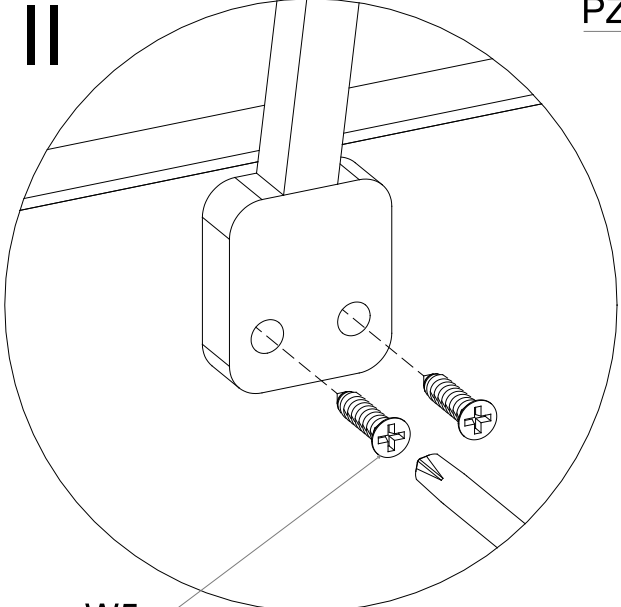

W5

I

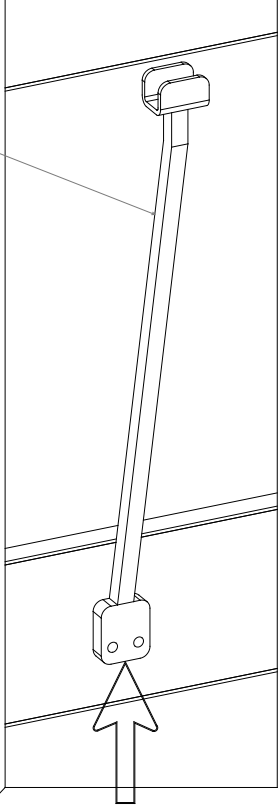

PZBCC

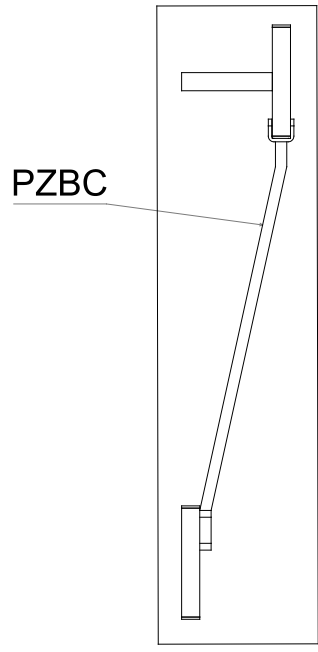

PZBCC

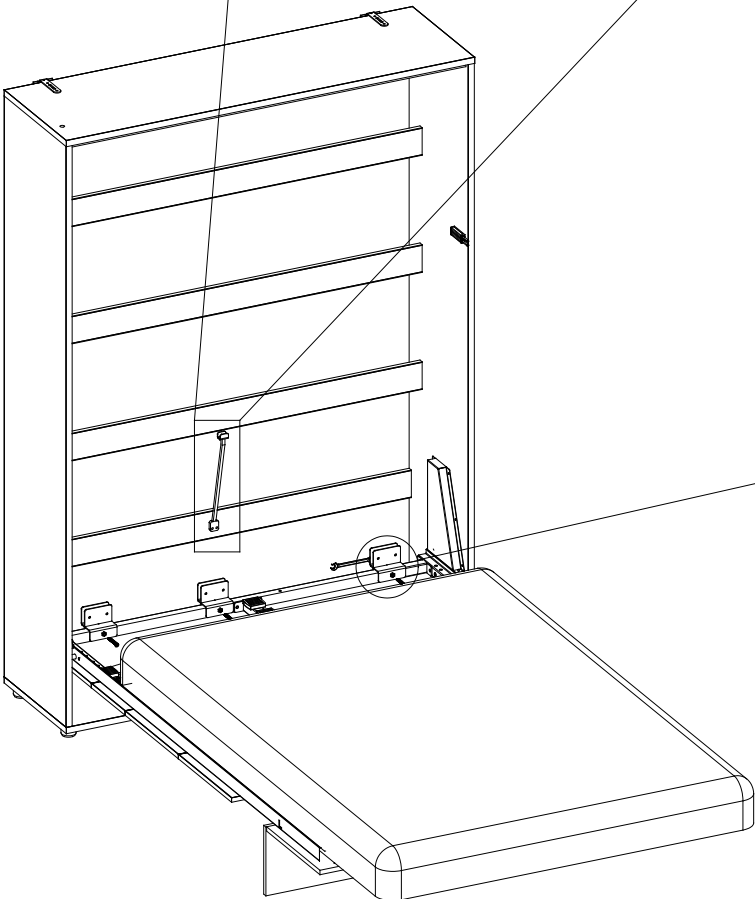

M6

P6

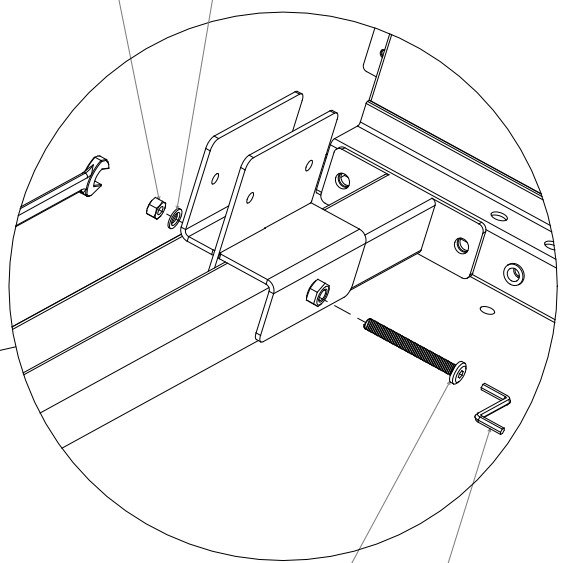

S56

KL4

6

A=B

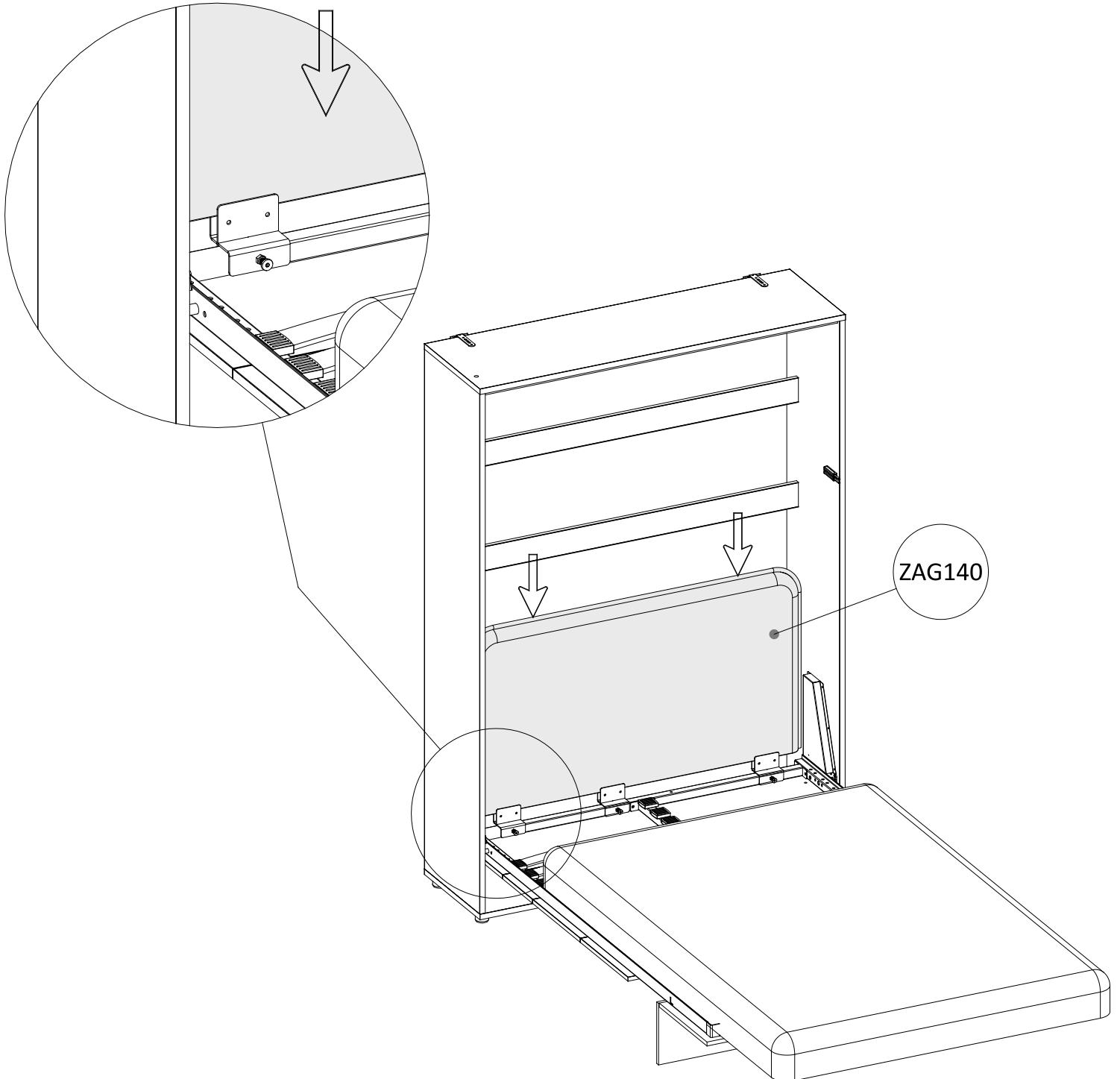

7

W14 4,5x20
6x

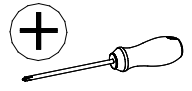

W14

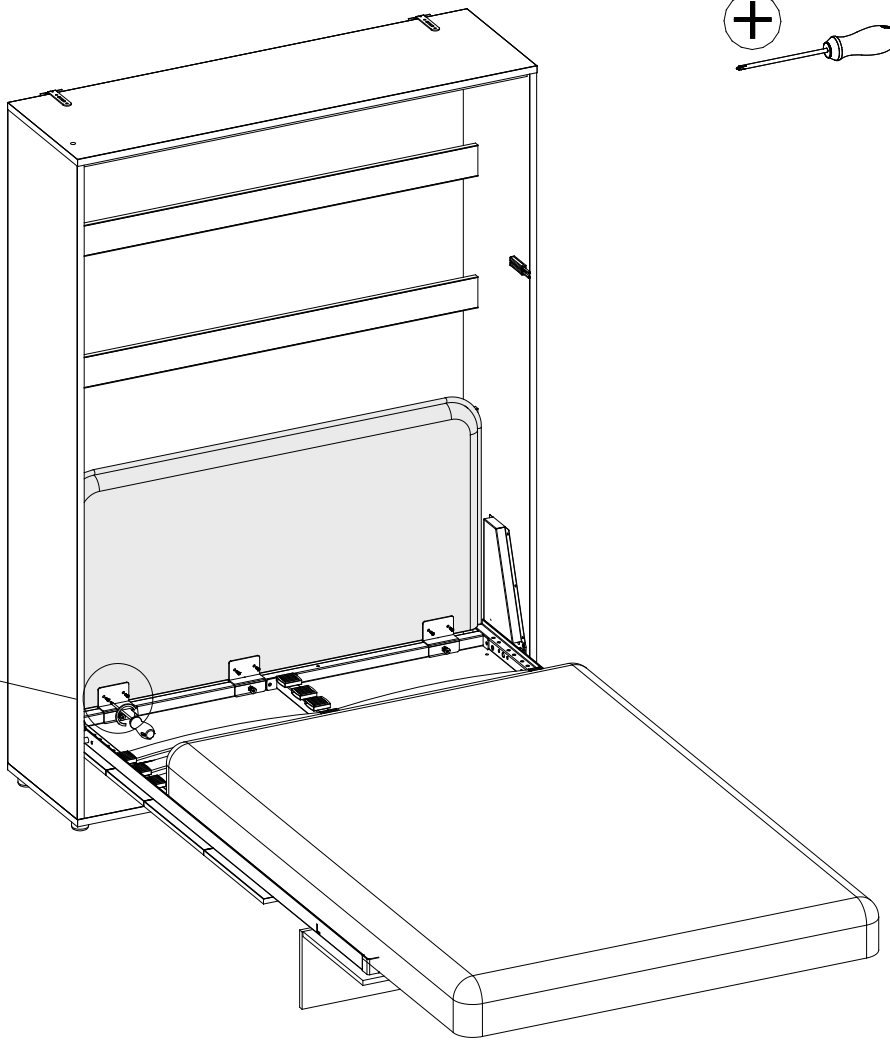
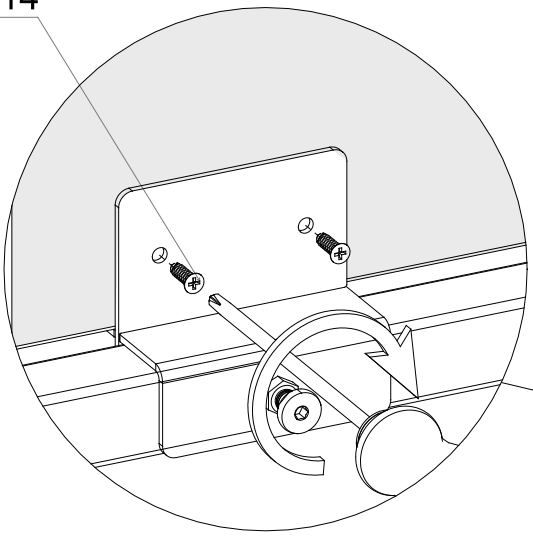

8

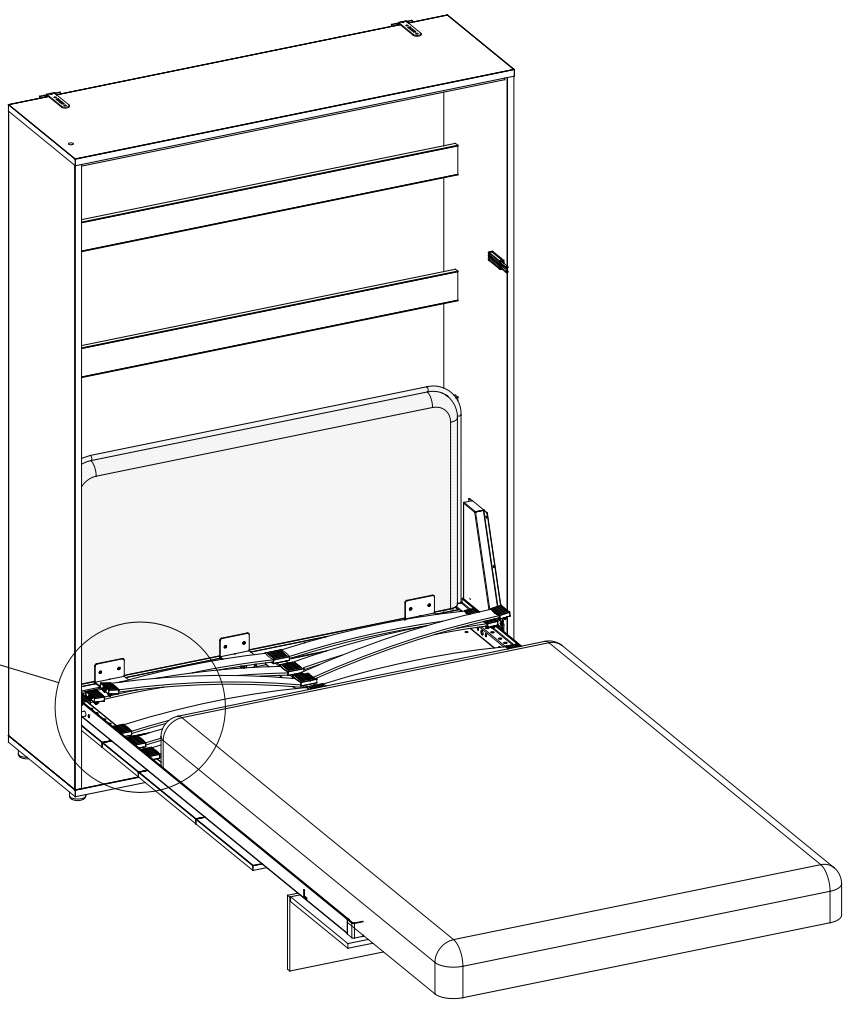
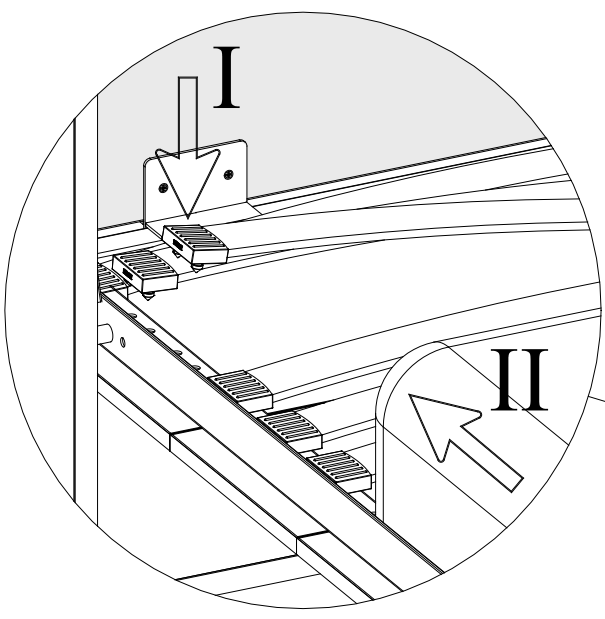

OPTIONAL LIGHT

